

Range: Modular detection for urinal

Ref: 52463 - Extra-flat detection

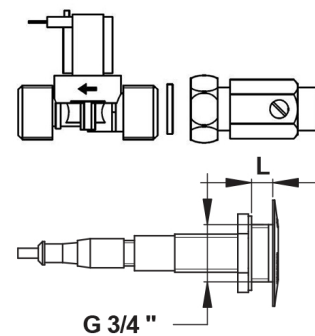
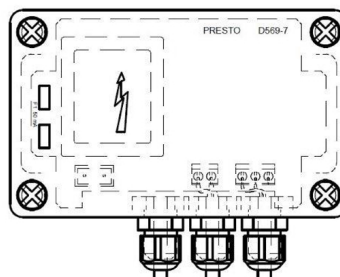

> Application :

- For urinal: induct mounting (for partition from 1 to 10mm)

> Working pressure :

- 1 to 5 bar

> Flow :

- 10 l/min with flow limiter
- Anti-water-hammering design

> Flow time :

- 7 seconds (\pm 1s)
- Adjustable from 3 to 16 seconds

> Range :

- Preset to 600 mm
- Range adjustable from 100 to 700 mm

> Hydraulic supply :

- On G 3/4" solenoid valve - Cold or mixed water

> Power supply :

- 230 V / 12V - 6VA Transformer (IP65 casing) included

> Delivered with :

- 1 IP65 detection cell - For partitions 1 to 10 mm thick and 2m of cable
- 1 G 3/4" solenoid valve
- 1 Stop valve
- Transformer (IP65 casing)
- Instruction manual

> Standards & approvals :

- Molded chrome-plated body in accordance with EN 12540
- 200-hour neutral salt spray resistant (NSS) in accordance with ISO 9227
- Security transformer in accordance with EN 60 742

